

## Perspective View

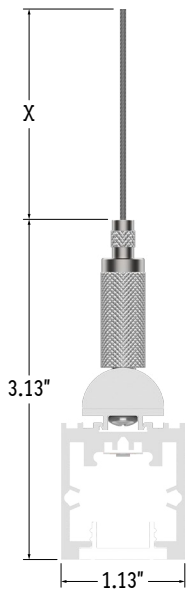

## Assembled End View



1. Measure area where fixtures will be installed. Use a chalk line to ensure a straight installation.
2. Determine the number of aircraft cable assemblies needed.  
**Note:** Use 2 aircraft cable assemblies clips per fixture segment.
3. Mark location where aircraft cables will be hung. Use two points of contact per fixture segment. Aircraft cables must be mounted to a surface capable of supporting the weight of the fixtures. Check with an engineer to determine appropriate mounting methods.
4. Mount aircraft cables at marked locations.  
**Recommendation:** 1/16" Aircraft Cable
5. Snap aircraft cable assemblies into fixtures using the same spacing, then twist cable gripper to lock aircraft cable assemblies in place.

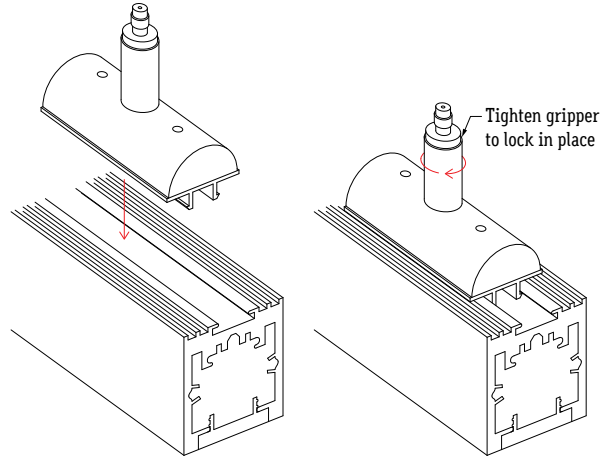

6. Unscrew and remove locking mechanism from cable gripper to reveal threads. Press down and hold the threads, then insert aircraft cable through locking mechanism and into the cable gripper. Insert cable until it reaches the bottom and stops. Release threads to hold in place, then replace locking mechanism.

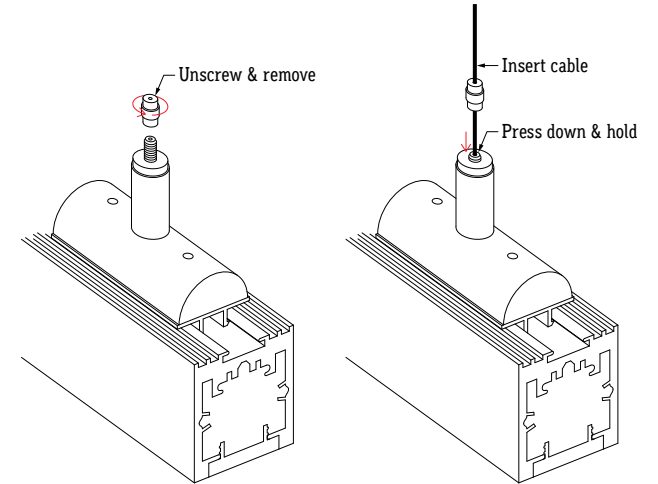

7. Release fixtures after all aircraft cables have been mounted. Make adjustments to the aircraft cable and position of aircraft cable assemblies as needed.

