**FEATURES**

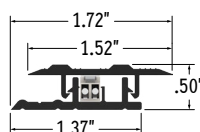
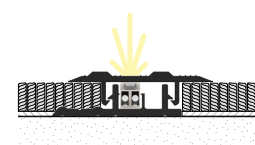
<b>APPLICATIONS</b>	Aisle and Path Lighting
<b>LAMP TYPE</b>	LEDs
<b>MOUNTING</b>	Adhesive
<b>WEIGHT</b>	0.34 lbs per foot
<b>CONSTRUCTION</b>	PVC Extrusion
<b>LENGTH</b>	Built to Order
<b>FINISH</b>	Matte Black
<b>LISTING</b>	Dry Location Only UL2108, CSA C22.2 #9 UL8750, CSA250
<b>INSTALLATION</b>	<a href="#">Link to Installation Instructions</a>
<b>ELECTRICAL</b>	
<b>DIMMING</b>	Forward Phase, 0-10V, Lutron, DMX, DALI
<b>LAMP WATTS</b>	0.25W per Lamp
<b>MAXIMUM LAMPS (Based on 5 Amps)</b>	432
<b>MAXIMUM LAMPS (Based on 4 Amps for Class II)</b>	344
<b>VOLTAGE</b>	24VDC
<b>WIRING</b>	Parallel
<b>SOCKET</b>	Custom
<b>DRIVER</b>	Remote (Sold Separately)
<b>TEMPERATURE RATINGS</b>	Operating / Startup: -20° to 48°C (-4° to 120°F) Storage: -40° to 76°C (-40° to 170°F)

**PRODUCT INFORMATION**

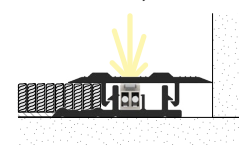
- For aisle, path, edge lighting
- 24 volts DC for easy and safe installation
- Long life, energy efficient LEDs
- Plug and light system
- Lead wires are typically 36" long and exit on one end

**READ ENTIRE GUIDE BEFORE STARTING INSTALLATION**

**IMPORTANT NOTICE:** VERIFY CORRECT LUMINAIRE WAS RECEIVED WITH CORRECT COLOR TEMPERATURE, VOLTAGE, AND WATTAGE BEFORE CUTTING OR INSTALLING. CALI WILL NOT BE RESPONSIBLE IF INCORRECT LUMINAIRE IS INSTALLED.

**END VIEW****MOUNTING OPTIONS**

**Carpet to Carpet**  
Note: Do not install AisleLITE on top of carpet.  
Install directly onto concrete or wood floor.



**Carpet to Wall**

**ELECTRICAL**

- AisleLITE products require a 24 Volt DC remote driver.
- To calculate driver size, determine Watts per Foot.  
**Example:** 6" Spacing = 2 LEDs per Foot x 0.25W = 0.5 Watts per Foot)
- Determine Length in Feet.  
**Example:** 30'
- Calculate Load: Multiply Watts per Foot x Length in Feet  
**Example:** 0.5W x 30' = 15W
- Choose a driver from catalog.  
**Example:** DRV30-E
- Determine maximum distance using Maximum Wire Length Table on drivers page.  
**Example:** 15 watts is between 10W and 20W. Using #14 wire, maximum distance is 98' from driver to first LED

**INSTALLATION RECOMMENDATIONS**

- Conduit raceway should be sleeved at one end for low voltage wires going to driver.

**INSTALLATION TOOLS REQUIRED**

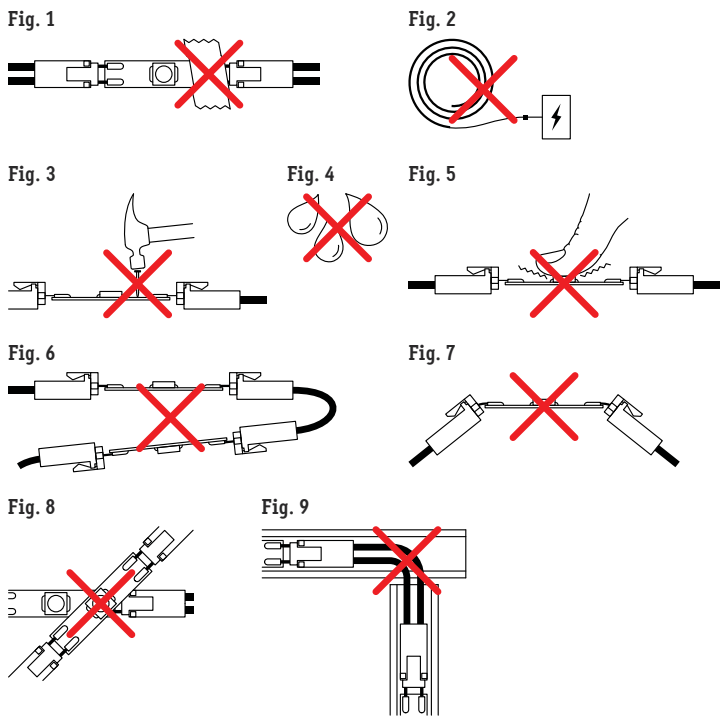
- Electric Hammer Drill
- 14.4 to 28 Volt Cordless Drill
- Phillips Bits
- Utility Knife
- Electrical Cord
- Marker
- Wire Stripper
- Long Nose Pliers
- Drill Bits - Concrete or Wood
- Electrical Three Ways
- Safety Glasses
- Measuring Tape
- Chalk Line

WARNING

When using AisleLITE for any application, basic safety precautions should always be followed to reduce the risk of fire, electric shock, and personal injury. AisleLITE must be installed in accordance with the NEC or CEC as applicable. CALI will not be responsible for any damage or malfunction caused by the following:

- Ensure power is off before installation begins, during replacements, additions, or repairs.
• Do not use AisleLITE if damaged, such as broken boards, loose connections, or frayed wire insulation.
• Do not install AisleLITE in hazardous locations.
• Do not cover AisleLITE with any material, as it may cause LEDs to overheat, melt, or ignite. (Fig. 1)
• Do not paint on or over fixture lens or LEDs.
• Do not overlap AisleLITE luminaires in any way.
• Only use AisleLITE with specified rated voltages.
• Surge protector must be set up for electrical power system to avoid damaging AisleLITE lighting system.
• Do not connect wires together, follow provided wiring diagrams.
• Do not cut wire while energized.
• Do not bend extrusion past permitted bend radius.
• Do not connect AisleLITE lightstrip to power source while spooled or coiled. (Fig. 2)
• Do not exceed maximum run lengths.
• Do not mount AisleLITE with staples, nails, or like means that might damage the insulation.
• Do not penetrate AisleLITE lightstrip with any foreign object. (Fig. 3)
• Do not mount AisleLITE inside tanks or enclosures of any kind.
• Do not force AisleLITE into a space that is too small.
• Do not submerge AisleLITE in any liquid. (Fig. 4)
• Do not install AisleLITE in any area that is continuously exposed to flowing or pooling water.
• Do not cut, puncture, or penetrate AisleLITE housing, end caps, or lens covers.
• Do not drop, bang, or rest weight upon AisleLITE.
• Do not apply excessive pressure to any part of AisleLITE lightstrip or LEDs. (Fig. 5)
• Do not bend AisleLITE power cord or continuous connector past permitted bend radius.
• Do not install AisleLITE lightstrip in a zig zag fashion. (Fig. 6)
• Do not fold, crease, or twist AisleLITE lightstrip. (Fig. 7)
• Do not bend lightstrip along a horizontal plane.
• Do not overlap AisleLITE at any location. (Fig. 8)
• Do not cross or overlap extrusions and twist lightstrip to overlap. (Fig. 9)
• Do not install AisleLITE in places where the power cord is subject to continuous flexing.
• Do not twist continuous connector or power cord.
• Do not hold, carry, or suspend AisleLITE by the power cord.

FIGURES



CLEANING MATERIALS

The use of solvents and/or cleaners which are not compatible with polycarbonate will result in the softening, crazing, and/or cracking of the plastic part. This is especially true of polycarbonate lamps and mounting bases which may be under stress in their normal applications.

COMPATIBLE WITH POLYCARBONATE

- Mild soap and water
• Mineral Spirits
• Isobutyl alcohol
• VM and P Naphtha
• Varsol No.2
• Mexane
• Freone TF and TE-35
• Ethanol
• Dirtex
• 2% Sol. Reg. Joy
• 10% Sol Bon Ami
• White Kerosene
• Methyl alcohol
• Heptane
• Petroleum Ether/65 degrees C
• Isopropyl alcohol
• Lacryl PCL-2035 polycarbonate cleaner

NOT COMPATIBLE WITH POLYCARBONATE

- Trichlor
• Gasoline
• Liquid Detergents
• Acetone
• Carbon Tetrachloride
• Pink Lux (Phosphate free)
• Triclene
• Chlorinated Hydrocarbons
• #1 & #3 denatured alcohol
• Methyl Ethyl Keytone (MEK)
• Texize-8006, 8129, 8758
• MIBK
• Liquid Cleaner - 8211
• Toluol
• Agitene
• Benzol
• Ajax
• Kleenol Plastics
• Lysol
• Stanisol Naphtha
• Oils
• Lemon Joy (phosphate free)
• Diversol
• Lestoil

FORWARD PHASE (FP) DIMMING PROTOCOL

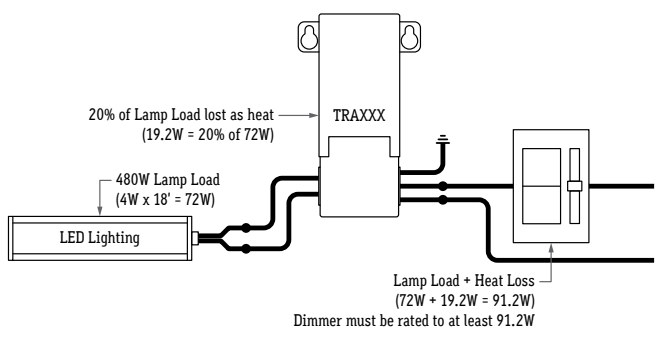
Technical Requirements For Control Equipment (Phase Dimming)

- Magnetic Low Voltage (MLV): Magnetic (core and coil, toroidal) transformer-supplied low voltage lighting.
Electrical Characteristic: Inductive
Special Requirements: Symmetric cycles (VDC <= 2), smooth turn off (positive and negative periods are equal for safe MLV transformer operation)

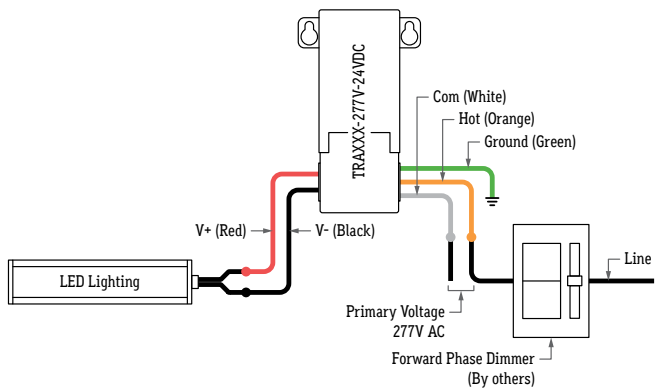
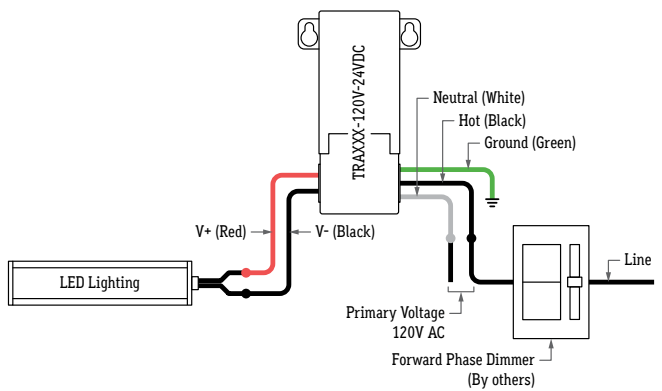


FORWARD PHASE DIMMER RATINGS

The stated VA (volt-ampere) rating is the rated capacity of the dimmer which includes the magnetic transformer heat losses and the lamp load. A transformer dissipates less than 20% of the connected load as heat. The lamp load plus the transformer loss determine the dimmer capacity required. See the example below.



FORWARD PHASE WIRING DIAGRAMS



0-10V (10V) DIMMING PROTOCOL

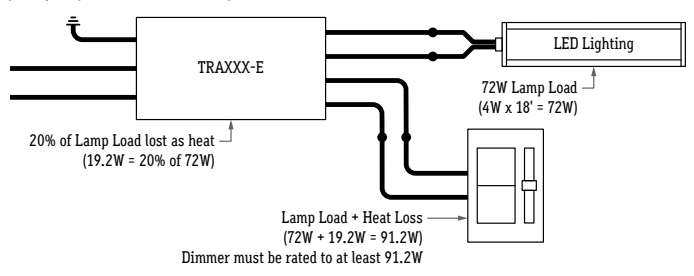
Available in 120 or 277 volts with either a dimmable integral or remote driver. The remote driver is available with 0-10V dimming capabilities. Consult factory for other dimming protocols available. The following applies to 0-10V dimming interfaces. A 0-10V fluorescent dimmer will not dim the LEDs.

Technical Requirements For Control Equipment (0-10V Dimming)

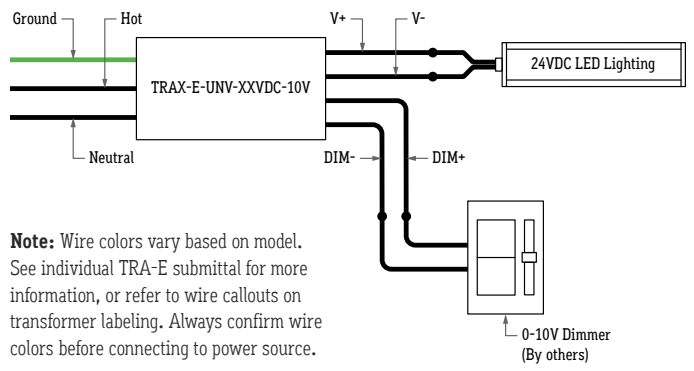
- The light output of the LEDs operated by the controllable LED driver is controlled by DC voltage applied to the control input leads (gray and violet).
The control device must be capable of accepting or sinking the DC current flow from the driver.
If the control bus is opened, or if the control device internally opens the control bus under some conditions, the voltage on the control bus will then be a function of the drivers, which is 10-15V.
If the control bus is shorted either by a mechanical switch in the control or by the circuitry of the control device, or inadvertently in the wiring, the current on the control bus will be less than 1.5mA.
As can be determined from the two items, simple two-level operation of the drivers can be achieved by proper usage and application of a simple open/closed switch on the control bus with maximum light being achieved when the switch is open and minimum light with the switch is closed.
The driver is intended to be used with control voltages between 0-10VDC volts peak maximum on the driver control leads.
Control equipment intended to control more than one driver must be capable of sinking the current supplied to the control bus by the maximum number of drivers specified for the control device.
Driver of various ratings may be mixed on the same control system.

0-10V DIMMER RATINGS

The stated VA (volt-ampere) rating is the rated capacity of the dimmer which includes the electronic transformer heat losses and the lamp load. A transformer dissipates less than 20% of the connected load as heat. The lamp load plus the transformer loss determine the dimmer capacity required. See the example below.



0-10V WIRING DIAGRAM



Note: Wire colors vary based on model. See individual TRA-E submittal for more information, or refer to wire callouts on transformer labeling. Always confirm wire colors before connecting to power source.

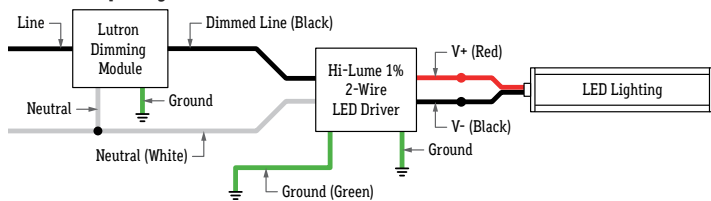
2-WIRE DIMMING PROTOCOL (Lutron LTEA)

Technical Requirements For Control Equipment (2-Wire Dimming)

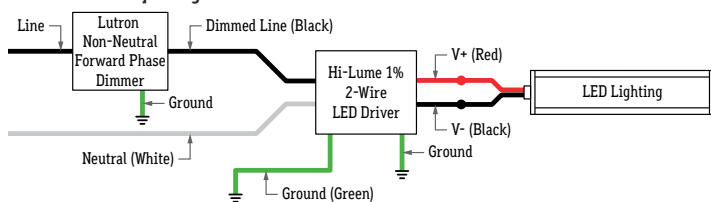
- The Hi-lume 1% 2-Wire LED Driver (LTEA2W) is a high performance LED driver that provides a smooth, continuous, flicker-free 1% dimming for virtually any LED fixture. Primary voltage is 120V and secondary side is 12VDC or 24VDC. A rated life time of 50,000 hours @tc -149°F (65°C). Inrush current: < 2A. Minimum operating temperature ta = 32°F (0°C).
Continuous, flicker-free dimming from 100% to 1%. Guaranteed compatibility with selected Maestro Wireless, RadioRA 2, HomeWorks QS, GRAFIK Eye QS, GRAFIK Systems, Quantum, and C•L Dimmers.

LTEA 2-WIRE WIRING DIAGRAMS (JA8 Compliant)

Controls Requiring Neutral



Controls Not Requiring Neutral



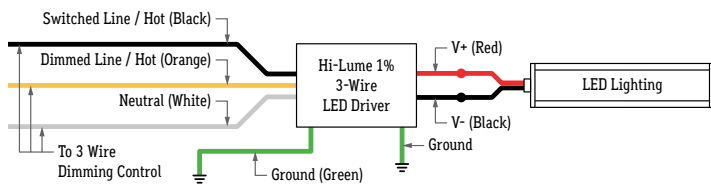
3-WIRE DIMMING PROTOCOL (Lutron L3DA)

Technical Requirements For Control Equipment (3-Wire Dimming)

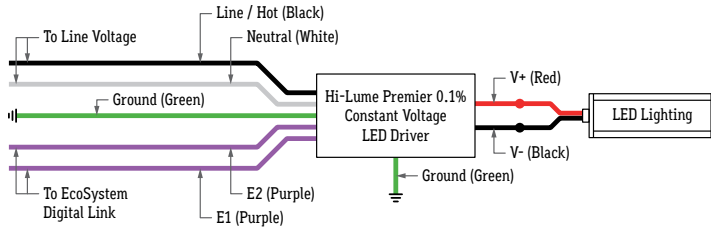
- Hi-lume 1% EcoSystem/3-Wire Driver (L3DA) is a high-performance LED driver that provides smooth, continuous 1% dimming for virtually any LED fixture, primary voltage is 120-277 V~ at 50/60 Hz and secondary side is 12VDC or 24VDC. A rated life time of 50,000 hours @tc -149°F (65°C). Inrush current: < 2A. Minimum operating temperature ta = 32°F (0°C).
Continuous, flicker-free dimming from 100% to 1%. Compatible with Energi Savr Node unit with EcoSystem, GRAFIK Eye QS control unit, PowPak dimming module with EcoSystem, and Quantum systems, allowing for integration into a planned or existing EcoSystem lighting control solution. Standard 3-wire, line-voltage phase-control technology for consistent dimming performance and compatibility with all Lutron 3-wire fluorescent controls.

L3DA 3-WIRE WIRING DIAGRAMS

3-Wire Controls



EcoSystem Digital Controls



Note: Colors shown on diagrams correspond to terminals on driver

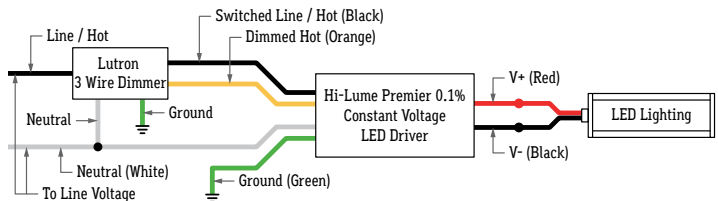
3-WIRE DIMMING PROTOCOL (Lutron L3D0)

Technical Requirements For Control Equipment (3-Wire Dimming)

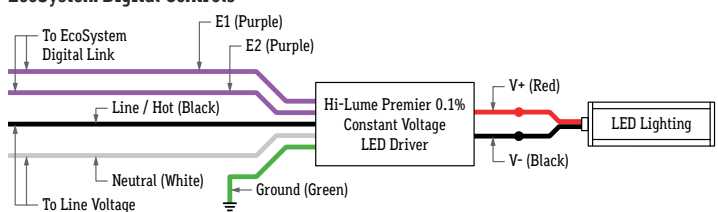
- Hi-lume Premier 0.1% EcoSystem / 3 Wire constant voltage 24V LED driver with Soft-on, Fade-to-Black. The Hi-lume Premier 0.1% Constant Voltage Driver (L3D0E) is a high-performance LED driver capable of controlling up to 96W of 24V constant voltage loads. This driver provides smooth and continuous dimming down to 0.1% low-end. It is ideal for use with strip lighting in applications such as coves, under or over cabinet lighting and pathway lighting. The driver is UL Listed with an integrated wiring compartment and can be mounted up to 150' away from the load.
Continuous, flicker-free dimming from 100% to 0.1%
Soft-on, Fade-to-Black operation for EcoSystem controls: fades smoothly between 0% and 0.1% when turned on and off for an incandescent like experience.
PWM dimming meets IEEE1789 over the entire dimming range.
UL Listed for United States and Canada (cULus®).
NOM certified for Mexico.
Field Adjustment Knob offers customer low-end light output tuning for better fixture-to-fixture matching.
Guaranteed dimming performance when used with Lutron controls:
- HomeWorks QS, Energi Savr Node units with EcoSystem controls, GRAFIK Eye QS with EcoSystem controls, PowPak with EcoSystem dimming modules, PowPak with EcoSystem wireless fixture controls, and Quantum systems, allowing for integration into a planned or existing EcoSystem lighting control solution.
- Lutron 3-wire controls and interfaces.
Protected from miswires of input power, up to 277 V~, to EcoSystem control inputs.
Rated lifetime of 50,000 hours at 40 °C (104 °F) ambient temperature and maximum loading.
FCC Part 15
- Class A (277 V~)
- Class B (120 V~)

L3D0 3-WIRE WIRING DIAGRAMS (JA8 Compliant)

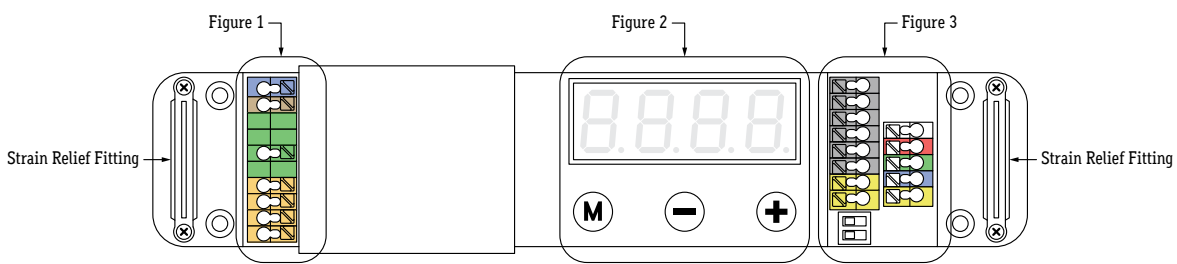
3-Wire Controls



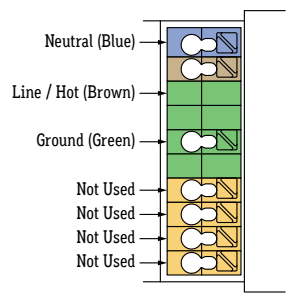
EcoSystem Digital Controls



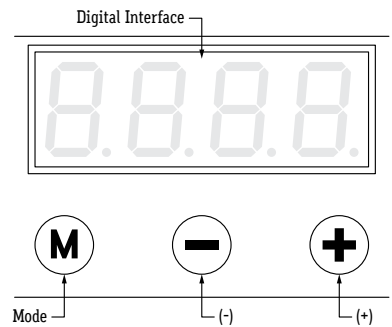
**DIAGRAM OF DRIVER**



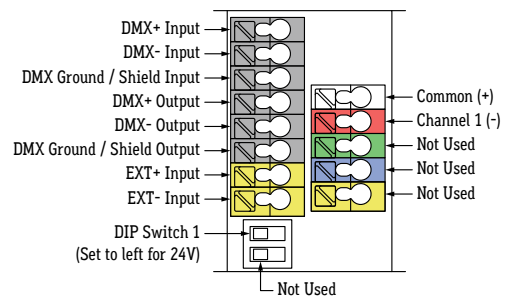
**FIGURE 1 (120V - 277V Input)**



**FIGURE 2 (Digital Interface Control)**

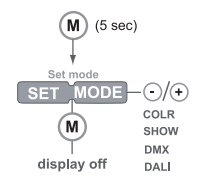


**FIGURE 3 (Output)**

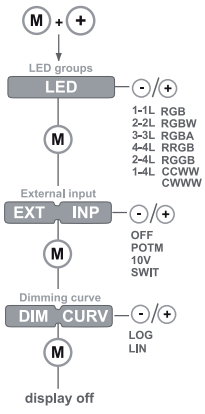


**OPERATION OF DIGITAL INTERFACE CONTROLS**

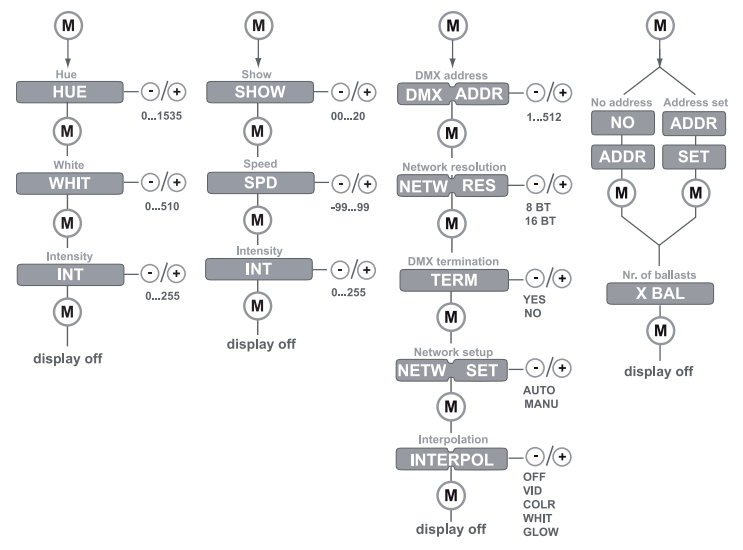
1. Select mode of operation.



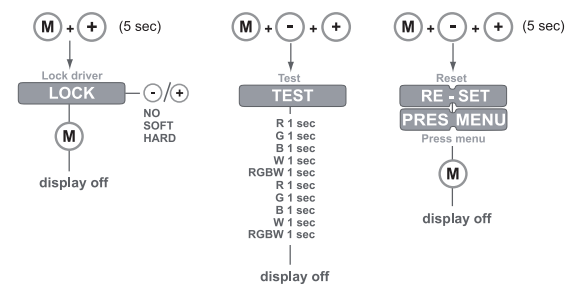
2. Set LED groups.



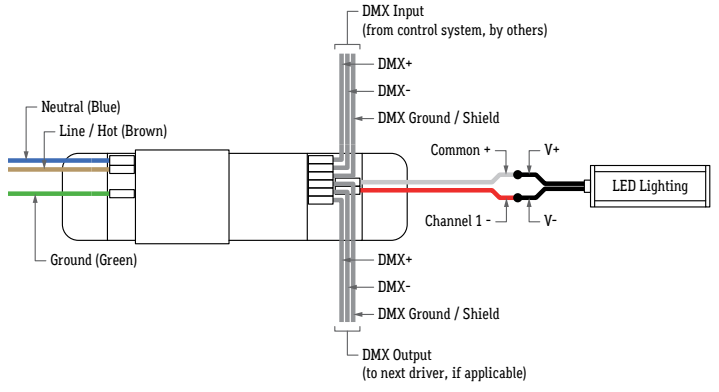
3. Standalone Operation (Color or Show) and Networked Operation (DMX or DALI)



4. Other functions (Lock Configuration, Visual Test, and Reset to Default)



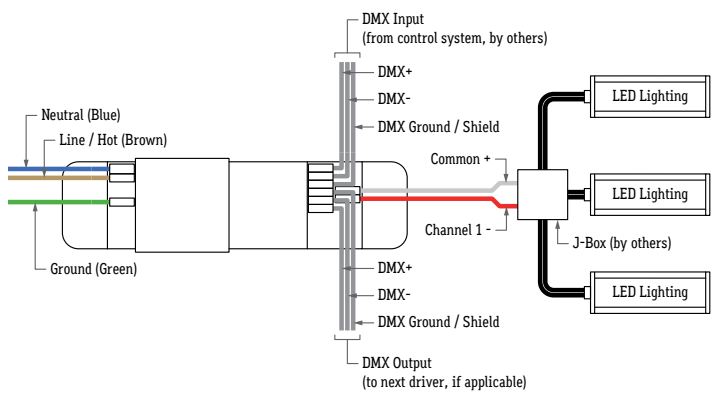
### WIRING WITH A SINGLE RUN



### NOTES

- Wire colors on diagram correspond to colors of driver terminals
- Driver load not to exceed 96W
- A DMX Control System (by others) must be used to operate the drivers
- Ensure DIP Switch 1 is set to ON (Left) to activate 24V operation
- DMX Address must be set for each driver. Default DMX address for each driver is 001.
- The last driver in a daisy chain sequence must be terminated (Refer to previous page for details)
- Up to 28 drivers may be daisy chained together using shielded cable specified for DMX wiring

### WIRING WITH MULTIPLE RUNS



### WIRING WITH MULTIPLE RUNS & DAISY CHAIN

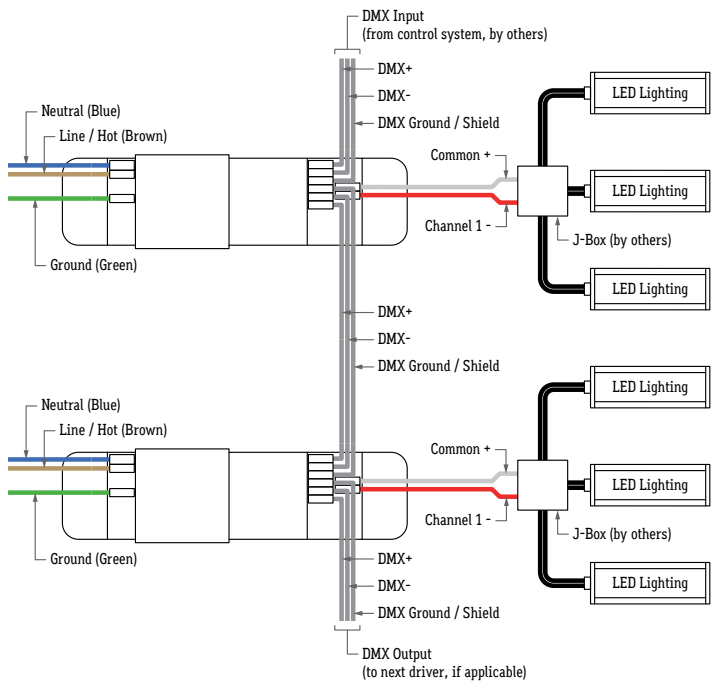


DIAGRAM OF DRIVER

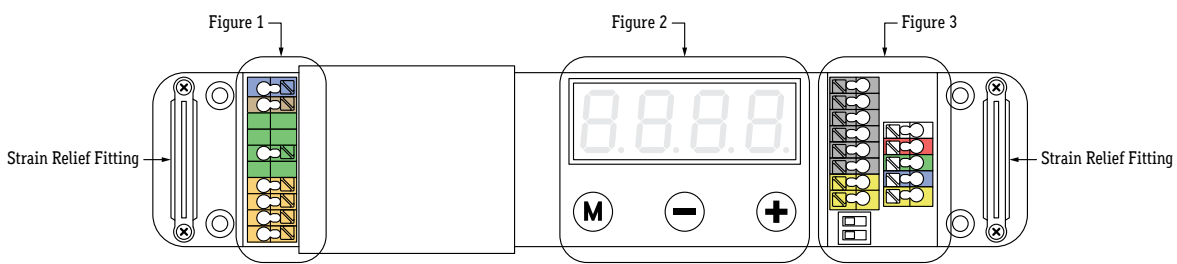


FIGURE 1 (120V - 277V Input)

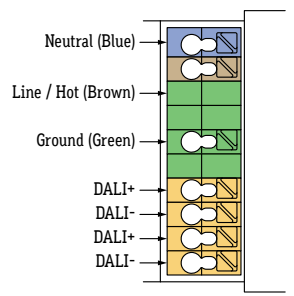


FIGURE 2 (Digital Interface Control)

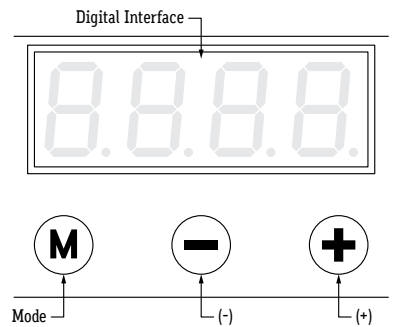
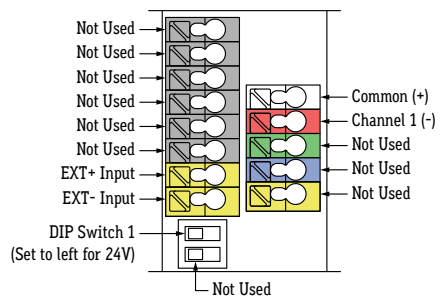
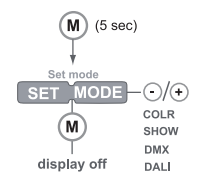


FIGURE 3 (Output)

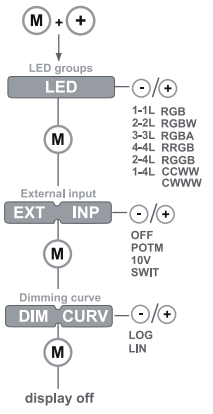


OPERATION OF DIGITAL INTERFACE CONTROLS

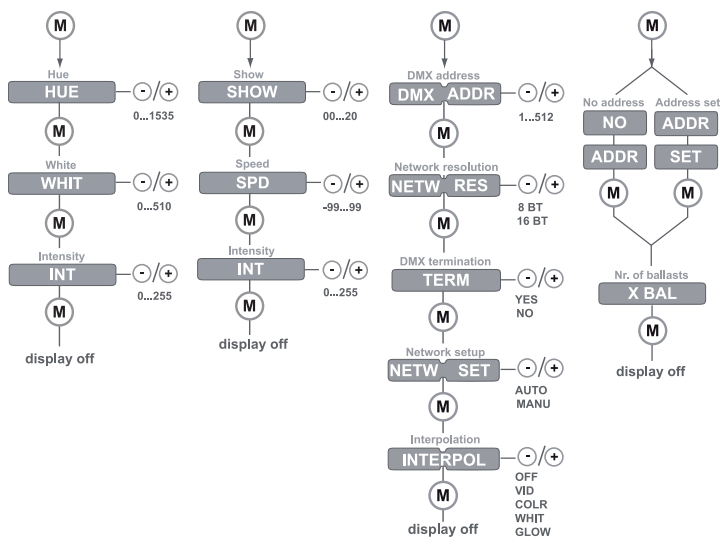
1. Select mode of operation.



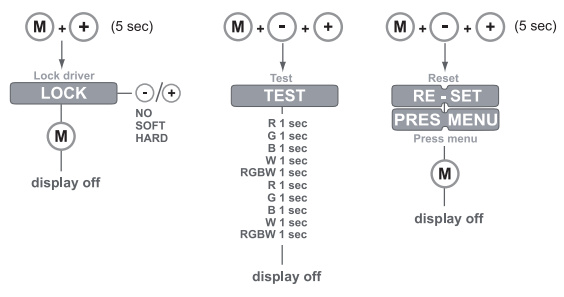
2. Set LED groups.



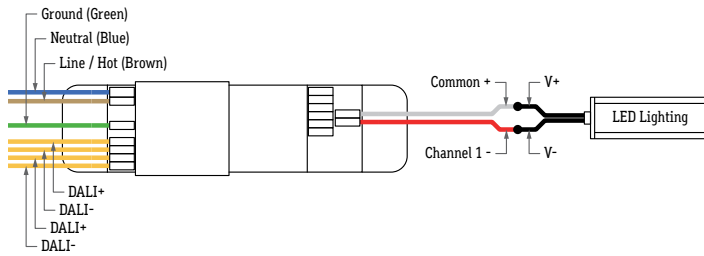
3. Standalone Operation (Color or Show) and Networked Operation (DMX or DALI)



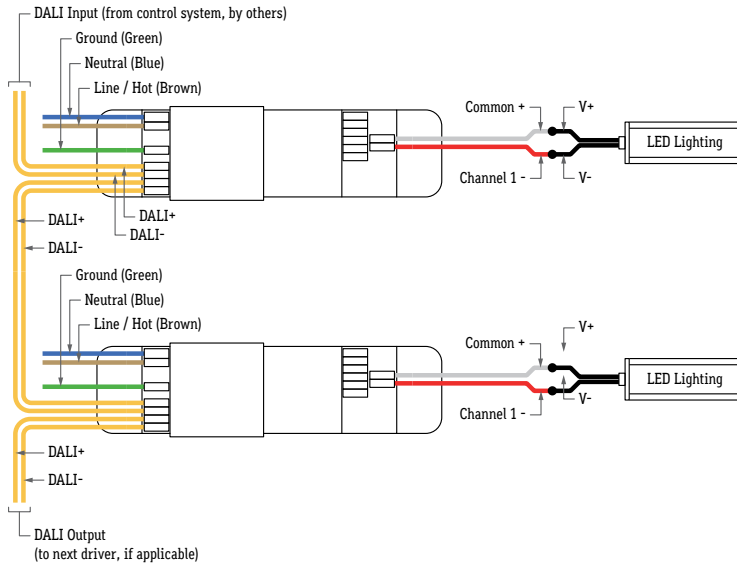
4. Other functions (Lock Configuration, Visual Test, and Reset to Default)



### WIRING WITH A SINGLE RUN



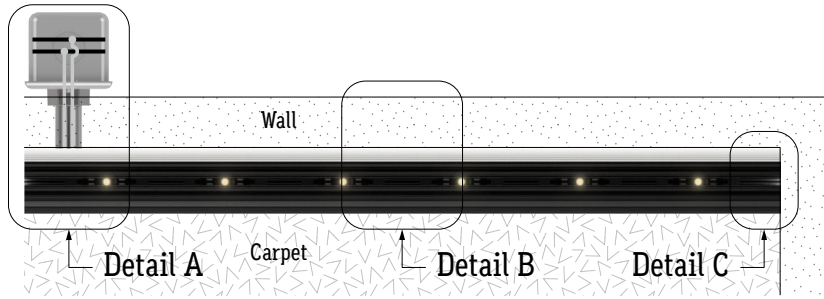
### WIRING WITH DAISY CHAIN



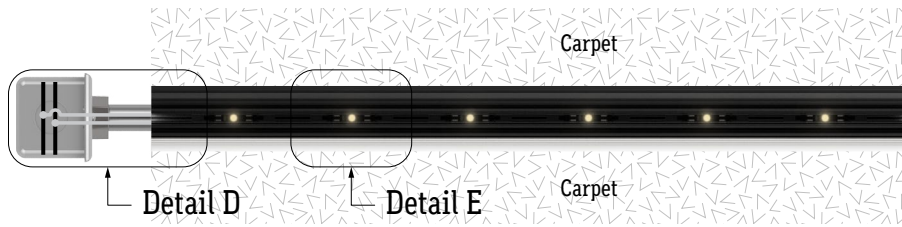
### NOTES

- Wire colors on diagram correspond to colors of driver terminals
- Driver load not to exceed 96W
- A DALI Control System (by others) must be used to operate the drivers
- Ensure DIP Switch 1 is set to ON (Left) to activate 24V operation
- DALI Address must be set for each driver.
- Up to 28 drivers may be daisy chained together using shielded cable specified for DALI wiring

### CARPET TO WALL



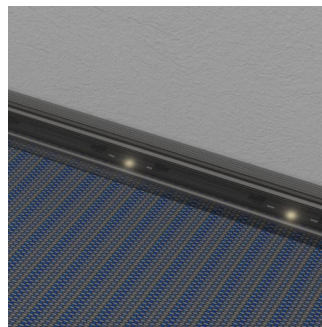
### CARPET TO CARPET



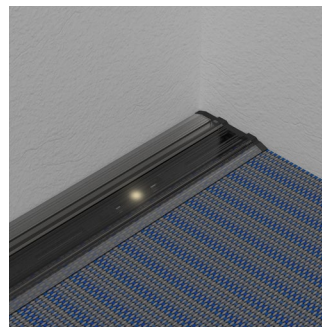
### DETAILS



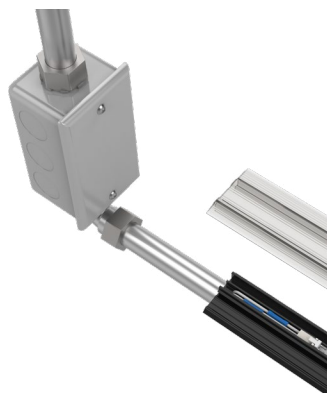
**Detail A**  
Wiring Connection to J-Box  
(J-Box by Others)



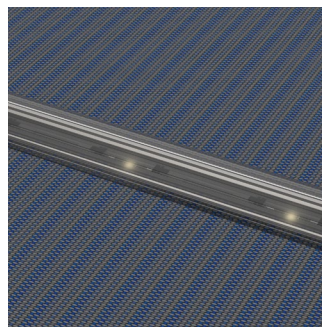
**Detail B**  
Path Extrusion - Carpet to Wall  
(AIL1700)



**Detail C**  
Terminating End with End Cap  
(AIL1700-ECR)



**Detail D**  
Wiring Connection to J-Box  
(J-Box by Others)



**Detail E**  
Path Extrusion - Carpet to Carpet  
(AIL1700)

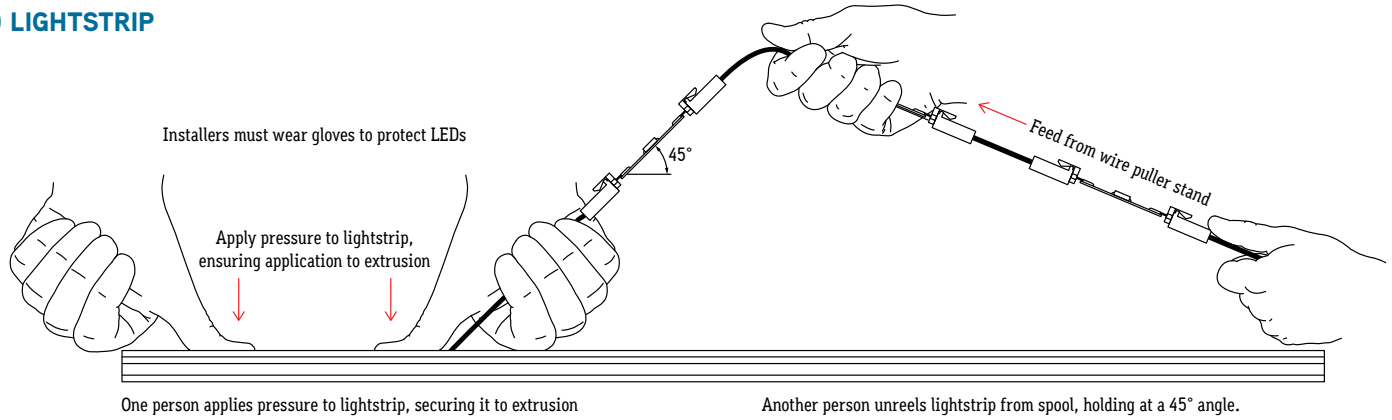
### APPLICATION GUIDELINES

- Follow the below diagrams and steps if applicable to your installation.
- LED lightstrip and modules require a team effort to ensure a secure and correct installation.
- Use a wire puller stand to prevent tangles, twists, and snags when installing.

### NOTE

- Extrusions are shipped to exact length of specified measurements.
- Due to cut increment restrictions ( $\pm 0.125"$  Tolerance), lightstrip is shipped to the closest measurement ordered. The lightstrip must be centered inside the extrusion.

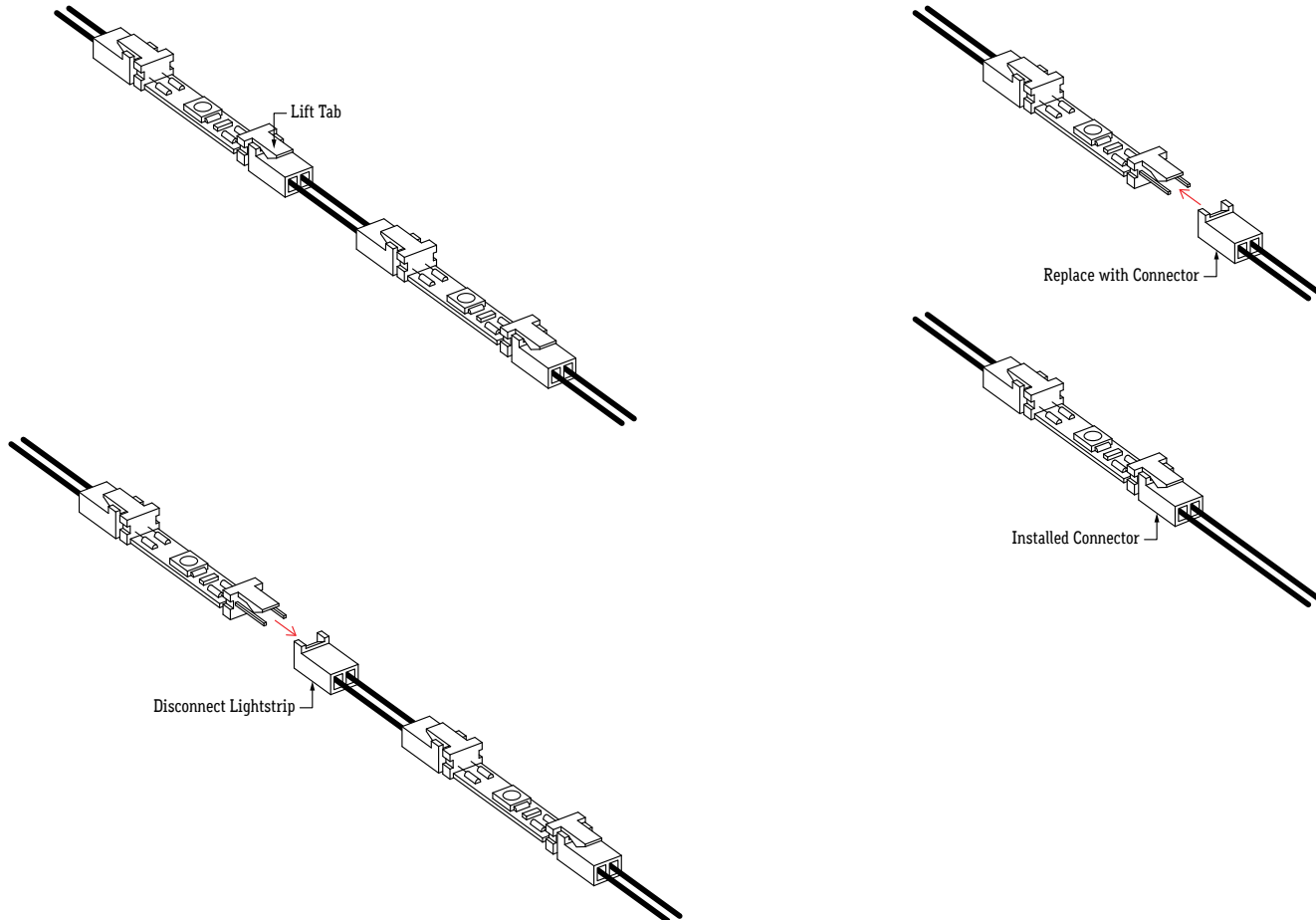
### LED LIGHTSTRIP

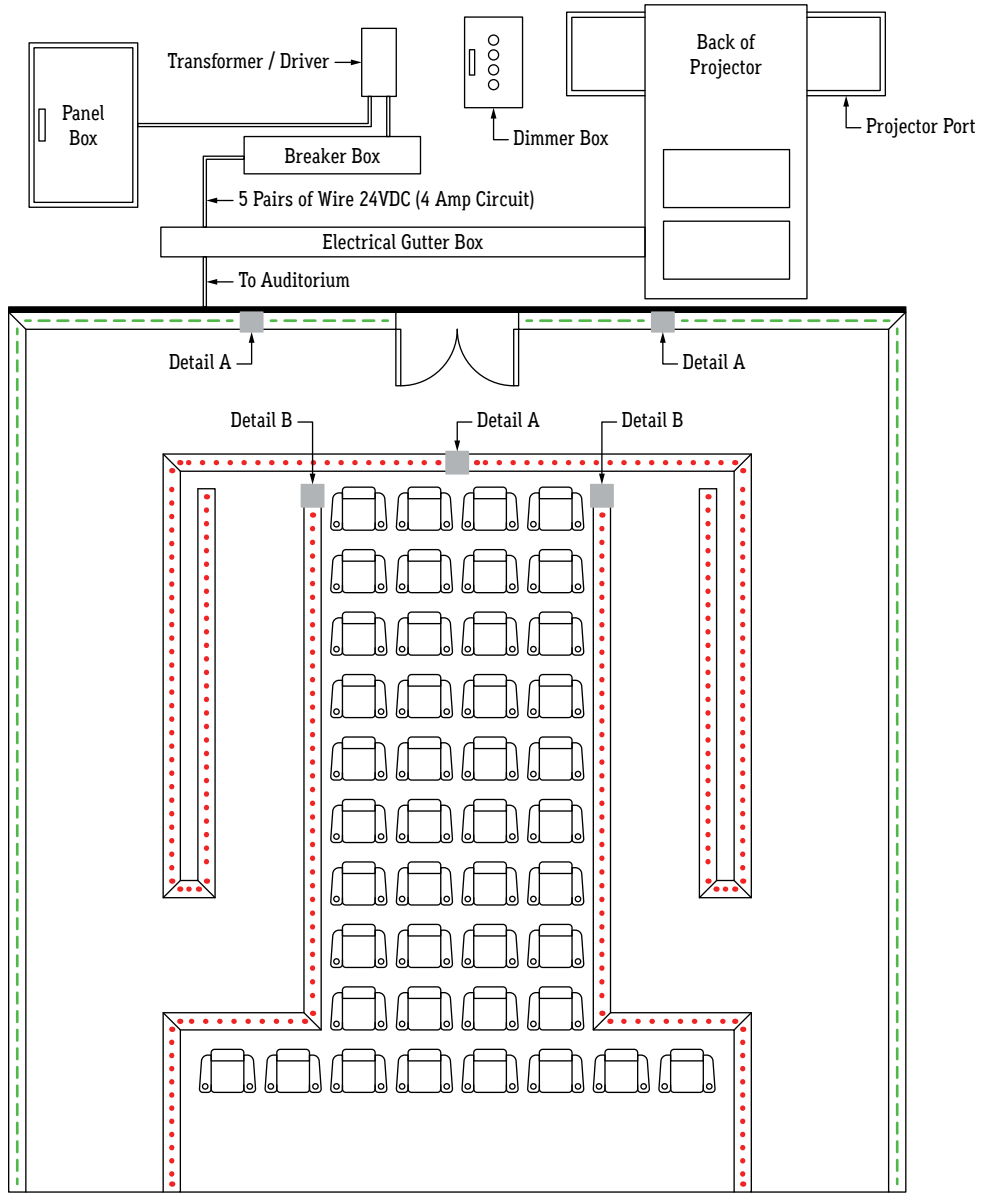


### CONNECTORS

1. Size lightstrip to desired length. Disconnect female terminal with wires from PCB by gently lifting tab to release.

2. Insert power connector or continuous connector into PCB male terminal. Ensure connector snaps in place.





**LEGEND**

PATTERN	DESCRIPTION
.....	Carpet to Floor (AIL1800)
-----	Carpet to Wall (AIL1700, AIL1800)

**TYPICAL LAYOUT FOR AUDITORIUM**  
(With less than 25 steps per side)

- Install 5 J-Boxes (By Others) in the following locations:
- J-Box 1: Right side of entrance
  - J-Box 2: Left side of entrance
  - J-Box 3: Front of entrance
  - J-Box 4: Left side of aisle
  - J-Box 5: Right side of aisle

**TRANSFORMER**

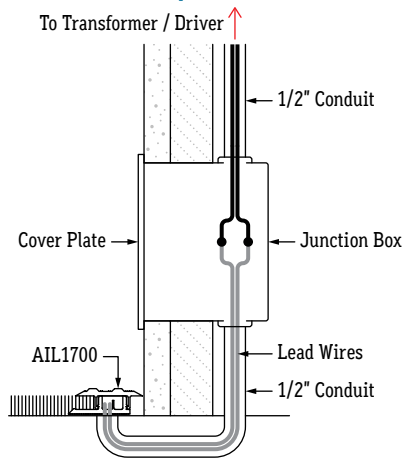
Typical transformer used is TRA300-6F-120V-24VDC (Magnetic Forward Phase)

See Features on page 1 for other dimming options

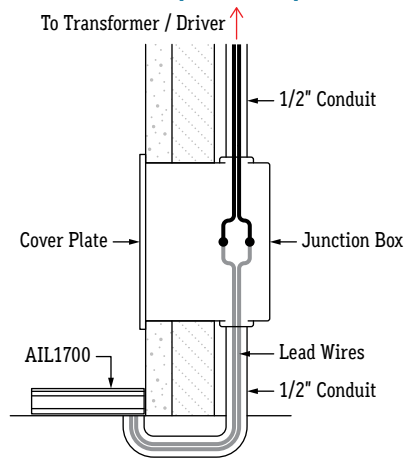
**Note:** Use separate wires for each circuit.

- Do not use a common ground.
- Use 14 Gauge Stranded Wire.
- Use separate colors to identify circuits.

**DETAIL A: Carpet to Wall**



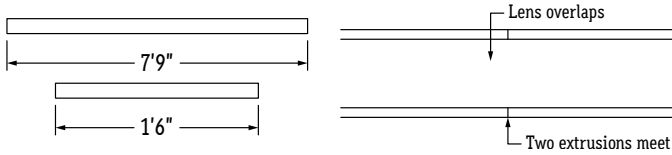
**DETAIL B: Carpet to Carpet**



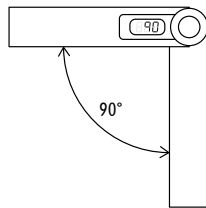
EXAMPLE: 90° MITER

Miter cuts are only to be performed on unassembled dry location products. Do not attempt to modify wet location products.

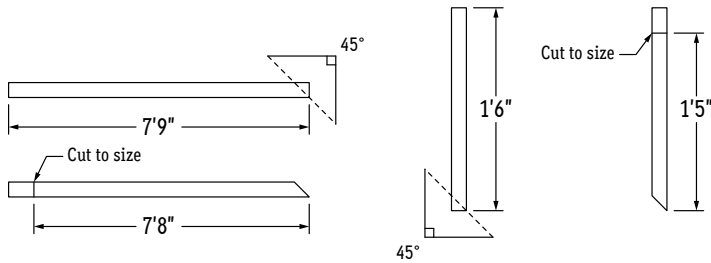
- 1. Measure area where mitered fixture will be installed. Cut extrusion and lens to size +1". Example: 7'8" extrusion to meet 1'5" extrusion. Cut extrusions to 7'9" and 1'6"
- Note:** Plan your cuts so that lens will always overlap where two extrusions meet. Overlapping lenses helps keep extrusions in line and prevents light leaks.



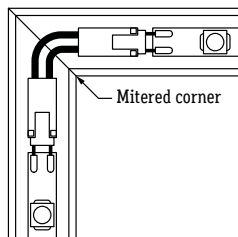
- 2. Measure angle where fixture will be mitered. Use an angle finder to determine exact angle. Example: 90° Angle



- 3. Divide measured angle by 2 ( $90^\circ \div 2 = 45^\circ$ ). Set miter saw to 45° and cut the end of each extrusion and lens where they will intersect. Verify the miter closes properly and fits in area, then trim excess extrusion on the end without the miter to exact size.

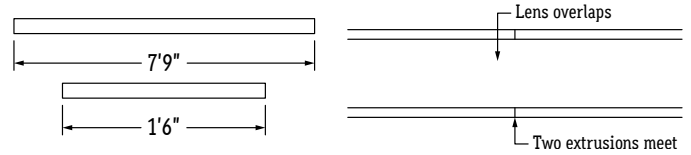


- 4. Use a continuous connector between mitered extrusions. Do not bend lightstrip to turn corner. Refer to Application Guidelines for connector steps.

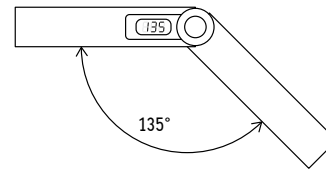


EXAMPLE: 135° MITER

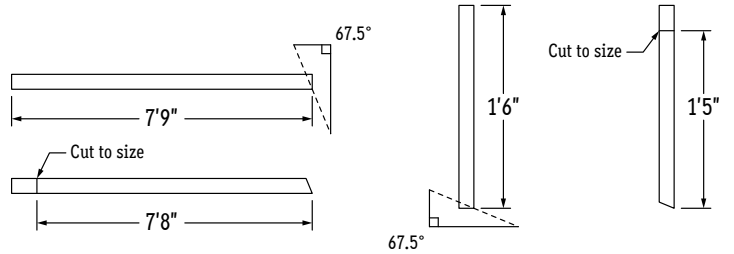
- 1. Measure area where mitered fixture will be installed. Cut extrusion and lens to size +1". Example: 7'8" extrusion to meet 1'5" extrusion. Cut extrusions to 7'9" and 1'6"
- Note:** Plan your cuts so that lens will always overlap where two extrusions meet. Overlapping lenses helps keep extrusions in line and prevents light leaks.



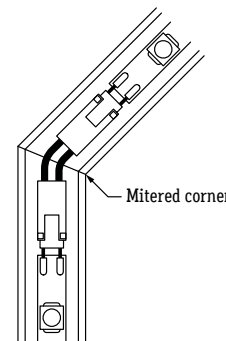
- 2. Measure angle where fixture will be mitered. Use an angle finder to determine exact angle. Example: 135° Angle



- 3. Divide measured angle by 2 ( $135^\circ \div 2 = 67.5^\circ$ ). Set miter saw to 67.5° and cut the end of each extrusion and lens where they will intersect. Verify the miter closes properly and fits in area, then trim excess extrusion on the end without the miter to exact size.

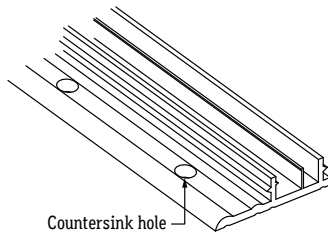


- 4. Use a continuous connector between mitered extrusions. Do not bend lightstrip to turn corner. Refer to Application Guidelines for connector steps.



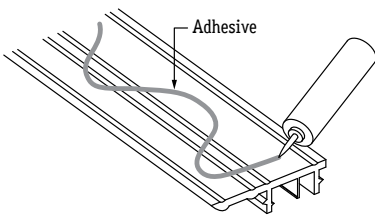
1. Measure area where fixtures will be installed. Use a chalk line to ensure a straight installation.

2. Lay extrusions along chalk line and drill at least 3 countersink holes per extrusion. Drill additional holes as needed.



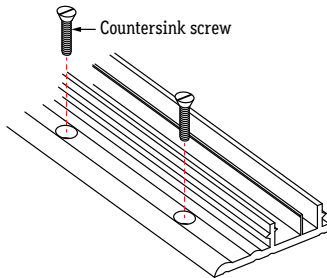
3. Apply adhesive along the underside of extrusions in a zig zag fashion, then lay extrusions along chalk line and secure in place.

Note: Surface must be flat.



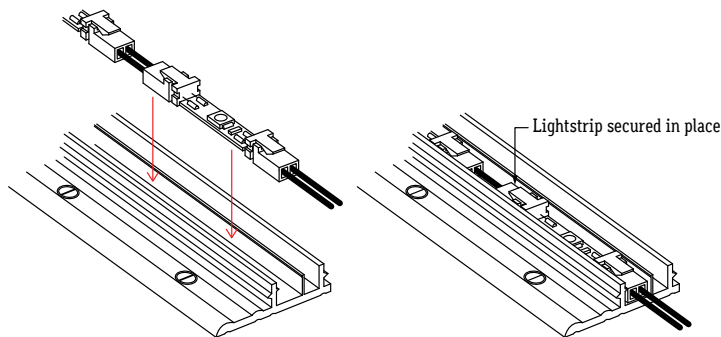
4. Drill holes in mounting surface, then mount extrusion to surface using countersink screws.

Note: Ensure extrusions are aligned. Misalignment will prevent lens from snapping in.

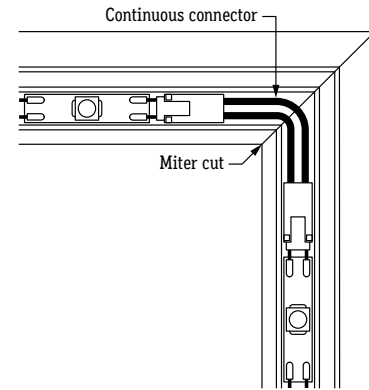


5. Install lightstrip into channel.

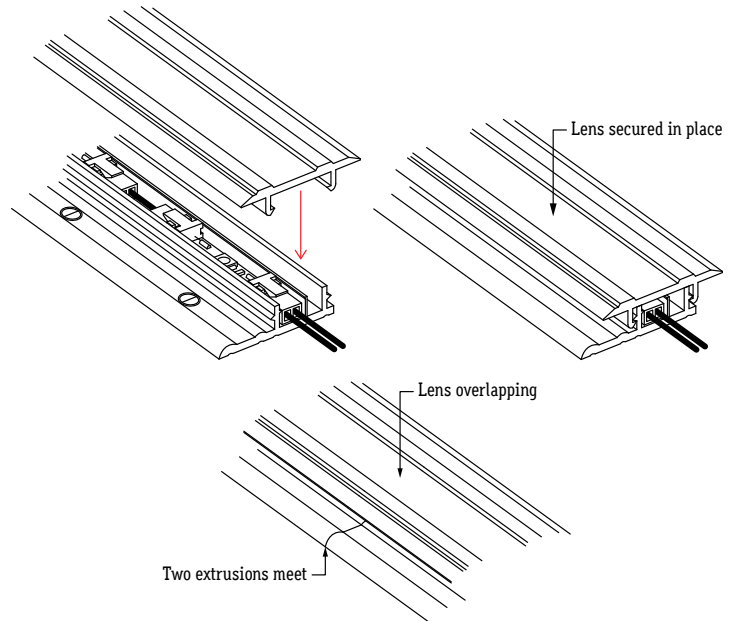
Note: Refer to application guidelines on page 10 to ensure correct installation.



6. If applicable, use continuous connectors to traverse corners and angles. Note: Refer to Miter Cut Guide on page 12 for details on creating miters.



7. Install lens into extrusion, overlapping where two extrusions meet. Plan your cuts so that the lens will always overlap where two extrusions meet. Overlapping lenses helps keep extrusions aligned and prevents light leaks.

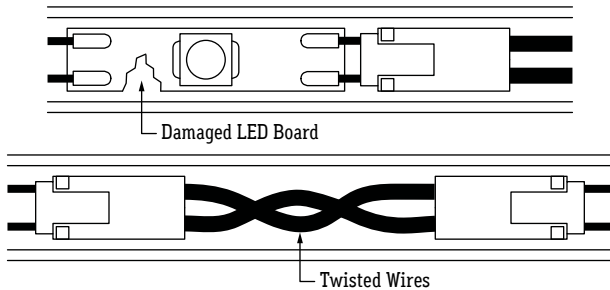


8. Perform continuity test steps on page 14 before connecting fixture to power source.

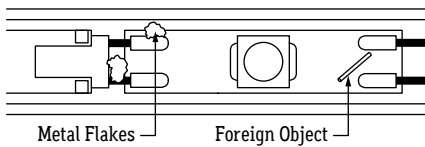
TROUBLESHOOTING TIPS

- Do not reset the breaker multiple times
If the unit is overloaded, the breaker will trip, shutting off the transformer and lights
If the breaker reset button has been held down by hand or any type of pressure, such as duct tape, or if the breaker has been reset multiple times without troubleshooting, the unit will:
- Burn the transformer bobbin
- Burn the thermal or magnetic breaker
- Burn the primary or secondary wires due to high amperage caused by overload
- Short circuit in line which will not allow the breaker to reset
- Damage the lighting

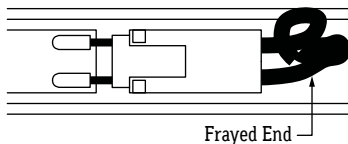
1. Turn off power before beginning. Check for any twisting or damage to the circuit in the LED lightstrip. If there is excessive damage and the circuit is broken, the lightstrip must be replaced.



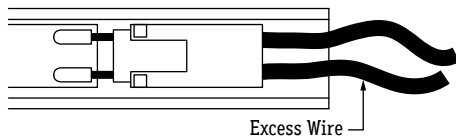
2. Check for metal particles or other foreign objects causing the short.



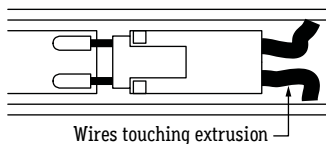
3. Check to make sure cuts in the lightstrip are clean and not frayed, causing positive and negative copper conductors to touch.



4. Ensure the run is not too long and excess wire or lightstrip is not overlapping.



5. Ensure conductors are not making contact with extrusion.



CONTINUITY TEST

A continuity test is performed to determine if electricity can pass through two points on an electrical circuit. This helps identify shorts or malfunctions in the line or fixture. Use a multimeter or continuity tester to perform the steps below.

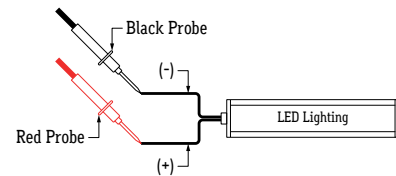
- Always perform a continuity test before connecting lighting to power source.
Malfunctions are not always as obvious as the lights not turning on.
A short or malfunction in the line or fixture will cause damage over time, ultimately damaging the lighting and voiding warranty.

1. Turn power off before beginning. Verify power is turned off by using a non-contact circuit tester. Touch the probe of the tester to positive wire of the power source. The tester will light up if an electrical current is detected.

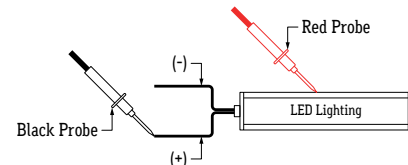
2. Setup your tester. First insert the black probe lead into the COM jack, then insert the red probe lead into the VΩ jack.

3. Verify that your tester is functional by touching probes together. The tester should light up, beep, or read 0Ω (ohms) of resistance.

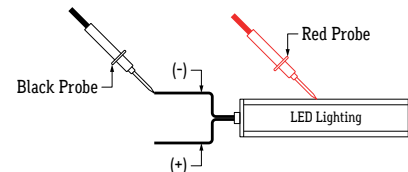
4. Touch the red probe to the positive (+) wire and the black probe to the negative (-) wire. If a conductive path is formed between the positive and negative wires, the multimeter will beep, flash, or read 0Ω (ohms). Troubleshoot to identify the malfunction in the line. If there is no conductive path, the multimeter will not show any feedback.



5. Touch the red probe to the fixture extrusion and the black probe to the positive (+) wire. If a conductive path is formed between the extrusion and the positive wire, the multimeter will beep, flash, or read 0Ω (ohms). Troubleshoot to identify the malfunction in the line. If there is no conductive path, the multimeter will not show any feedback.



6. Touch the red probe to the fixture extrusion and the black probe to the negative (-) wire. If a conductive path is formed between the extrusion and the negative wire, the multimeter will beep, flash, or read 0Ω (ohms). Troubleshoot to identify the malfunction in the line. If there is no conductive path, the multimeter will not show any feedback.



7. Set voltmeter to DC voltage and test power source. Confirm the correct voltage before connecting lighting to power source. If voltage reading is more than 1 volt higher than the marked output voltage, there is a problem with the power source or driver.

8. Connect power connector to power source. If LEDs do not turn on, flip polarity (+ -) or power source connection to power connector.

**MAXIMUM RUN BASED ON 80% LOAD OF MAGNETIC TRANSFORMER (TRA) MAXIMUM WATTAGE**

TRANSFORMER WATTAGE	80% LOAD	1.5W MAX RUN	2W MAX RUN	2.5W MAX RUN	3W MAX RUN	3.6W MAX RUN	4W MAX RUN	4.5W MAX RUN	5W MAX RUN	5.5W MAX RUN	6W MAX RUN	6.5W MAX RUN
5	4W	2.6'	2'	1.6'	1.3'	1.1'	1'	0.8'	0.8'	0.7'	0.6'	0.6'
10	8W	5.3'	4'	3.2'	2.6'	2.2'	2'	1.7'	1.6'	1.4'	1.3'	1.2'
20	16W	10.6'	8'	6.4'	5.3'	4.4'	4'	3.5'	3.2'	2.9'	2.6'	2.4'
35	28W	18.6'	14'	11.2'	9.3'	7.7'	7'	6.2'	5.6'	5.1'	4.6'	4.3'
40	32W	21.3'	16'	12.8'	10.6'	8.8'	8'	7.1'	6.4'	5.8'	5.3'	4.9'
50	40W	26.6'	20'	16'	13.3'	11.1'	10'	8.8'	8'	7.2'	6.6'	6.1'
60	48W	32'	24'	19.2'	16'	13.3'	12'	10.6'	9.6'	8.7'	8'	7.3'
75	60W	40'	30'	24'	20'	16.6'	15'	13.3'	12'	10.9'	10'	9.2'
90	72W	48'	36'	28.8'	24'	20'	18'	16'	14.4'	13.1'	12'	11.1'
150	120W	80'	60'	48'	40'	33.3'	30'	26.6'	24'	21.8'	20'	18.4'
200	160W	106.6'	80'	64'	53.3'	44.4'	40'	35.5'	32'	29.1'	26.6'	24.6'
250	200W	133.3'	100'	80'	66.6'	55.5'	50'	44.4'	40'	36.3'	33.3'	30.7'
300	240W	160'	120'	96'	80'	66.6'	60'	53.3'	48'	43.6'	40'	36.9'

**PREVENTING VOLTAGE DROP**

The maximum wire length to prevent voltage drop refers to the wire that is used between the transformer and 1st LED of the lighting fixture. If the gauge wire is too small, the fixture will not receive correct voltage.

**Example:** LED luminaire requires 24VDC to operate effectively. If the wire gauge is too small to carry the 24VDC current from the transformer, the voltage can shrink to 16VDC, which is insufficient to power the lighting.



**WATTS (VA) PER CIRCUIT (Maximum wire length to prevent voltage drop)**

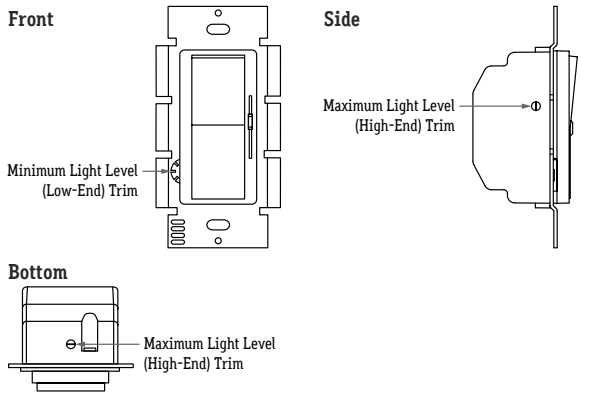
WIRE SIZE	VOLTAGE	5 VA	10 VA	20 VA	35 VA	40 VA	50 VA	60 VA	75 VA	90 VA	150 VA	200 VA	250 VA	300 VA	500 VA	600 VA
14GA	12V	51'	49'	44'	39'	37'	35'	32'	30'	25'	18'	14'	9'	7'		
14GA	24V	103'	98'	89'	80'	75'	70'	66'	61'	51'	37'	28'	18'	14'		
12GA	12V	81'	76'	70'	63'	59'	55'	52'	48'	40'	29'	22'	14'	11'		
12GA	24V	162'	155'	140'	125'	118'	111'	103'	96'	81'	59'	44'	29'	22'		
10GA	12V	129'	123'	112'	100'	94'	88'	82'	76'	65'	47'	35'	24'	18'	7'	4'
10GA	24V	258'	247'	223'	200'	188'	176'	165'	153'	129'	94'	71'	48'	36'	15'	9'
8GA	12V	205'	196'	177'	158'	149'	140'	130'	121'	102'	74'	55'	37'	27'	12'	7'
8GA	24V	411'	392'	355'	318'	299'	280'	262'	243'	205'	149'	112'	75'	55'	24'	14'

**TRANSFORMER CARE**

- Do not submerge transformers in any liquid
- Do not leave any exposed wires
- Do not cover transformer without proper ventilation
- Do not install damaged transformer
- Do not exceed maximum load

**DIMMER TRIM VALUES**

- Set dimmer trim value as needed to prevent flickering and irregular dimming
- **Note:** Review dimmer specs for trim value adjustment





CALIFORNIA  
ACCENT  
LIGHTING  
INC

**AIL1700** | INSTALLATION

Electronic Transformer Remote Driver (TRA-E)

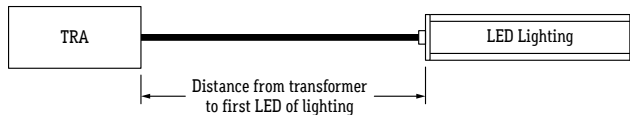
#### MAXIMUM RUN BASED ON 80% LOAD OF ELECTRONIC TRANSFORMER (TRA-E) MAXIMUM WATTAGE

TRANSFORMER WATTAGE	80% LOAD	1.5W MAX RUN	2W MAX RUN	2.5W MAX RUN	3W MAX RUN	3.6W MAX RUN	4W MAX RUN	4.5W MAX RUN	5W MAX RUN	5.5W MAX RUN	6W MAX RUN	6.5W MAX RUN
16	12.8W	8.5'	6.4'	5.1'	4.2'	3.5'	3.2'	2.8'	2.5'	2.3'	2.1'	1.9'
25	20W	13.3'	10'	8'	6.6'	5.5'	5'	4.4'	4'	3.6'	3.3'	3.1'
40	32W	21.3'	16'	12.8'	10.6'	8.8'	8'	7.1'	6.4'	5.8'	5.3'	4.9'
60	48W	32'	24'	19.2'	16'	13.3'	12'	10.6'	9.6'	8.7'	8'	7.3'
80	64W	42.6'	32'	25.6'	21.3'	17.7'	16'	14.2'	12.8'	11.6'	10.6'	9.8'
90	72W	48'	36'	28.8'	24'	20'	18'	16'	14.4'	13.1'	12'	11.1'
96	76.8W	51.2'	38.4'	30.7'	25.6'	21.3'	19.2'	17.1'	15.36'	13.9'	12.8'	11.8'
120	96W	64'	48'	38.4'	32'	26.6'	24'	21.3'	19.2'	17.4'	16'	14.7'
150	120W	80'	60'	48'	40'	33.3'	30'	26.6'	24'	21.8'	20'	18.4'
185	148W	98.6'	74'	59.2'	49.3'	41.1'	37'	32.8'	29.6'	26.9'	24.6'	22.7'
240	192W	128'	96'	76.8'	64'	53.3'	48'	42.6'	38.4'	34.9'	32'	29.5'
320	256W	170.6'	128'	102.4'	85.3'	85.3'	64'	56.8'	51.2'	46.5'	42.6'	39.3'

#### PREVENTING VOLTAGE DROP

The maximum wire length to prevent voltage drop refers to the wire that is used between the transformer and 1st LED of the lighting fixture. If the gauge wire is too small, the fixture will not receive correct voltage.

**Example:** LED luminaire requires 24VDC to operate effectively. If the wire gauge is too small to carry the 24VDC current from the transformer, the voltage can shrink to 16VDC, which is insufficient to power the lighting.



#### WATTS (VA) PER CIRCUIT (Maximum wire length to prevent voltage drop)

WIRE SIZE	VOLTAGE	16 VA	25 VA	40 VA	60 VA	80 VA	90 VA	96 VA	120 VA	150 VA	185 VA	240 VA	320 VA
14GA	12V	46'	42'	37'	32'	28'	25'	23'	21'	18'	16'	11'	4'
14GA	24V	93'	84'	75'	66'	56'	51'	47'	42'	37'	33'	23'	9'
12GA	12V	74'	66'	59'	52'	44'	40'	37'	33'	29'	26'	18'	7'
12GA	24V	147'	132'	118'	103'	89'	81'	74'	67'	59'	52'	37'	15'
10GA	12V	117'	106'	94'	82'	71'	65'	59'	53'	47'	41'	30'	12'
10GA	24V	235'	211'	188'	165'	141'	129'	118'	106'	94'	83'	59'	24'
8GA	12V	186'	168'	149'	130'	112'	102'	93'	84'	74'	65'	46'	18'
8GA	24V	374'	336'	299'	262'	224'	205'	187'	168'	149'	131'	93'	37'

#### TRANSFORMER CARE

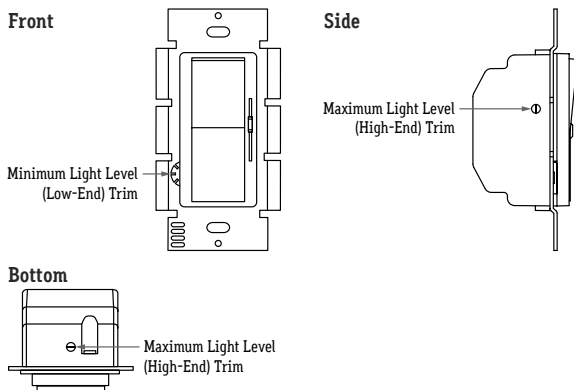
- Do not submerge transformers in any liquid
- Do not leave any exposed wires
- Do not cover transformer without proper ventilation
- Do not install damaged transformer
- Do not exceed maximum load

#### MOUNTING INSIDE AN ENCLOSURE

- Only mount drivers inside enclosures rated for your application
- Always ground drivers to enclosure
- Do not mount drivers without an enclosure
- Use enclosure knockouts and water-tight cordgrips when applicable

#### DIMMER TRIM VALUES

- Set dimmer trim value as needed to prevent flickering and irregular dimming
- **Note:** Review dimmer specs for trim value adjustment



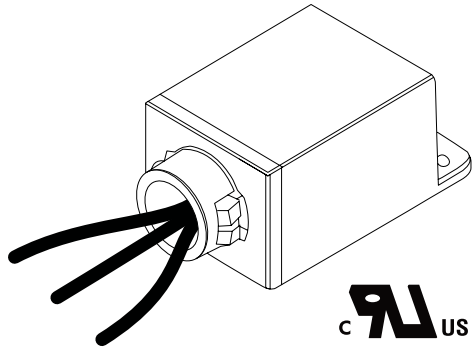
CALIFORNIA ACCENT LIGHTING, INC.

2820 E. Gretta Lane, Anaheim, CA 92806

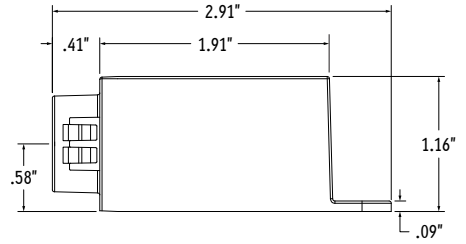
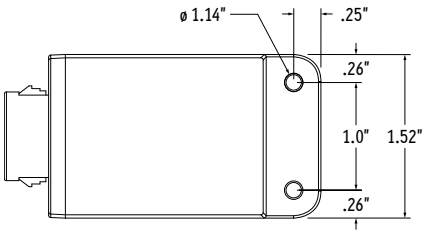
ph. 800.921.CALI (2254) | fx. 714.535.7902 | info@calilighting.com | calilighting.com

© CALI. All rights reserved. CALI reserves the right to make changes or withdraw specifications without prior notice.

**aisleLITE™**  
Manufactured in the U.S.A.



**CASE DIMENSIONS**



**SURGE PROTECTOR SPECIFICATIONS**

MODEL	INPUT VOLTAGE	SURGE PROTECTION LEVEL	MOUNTING	ENCLOSURE MATERIAL	INPUT LEADS	INPUT FREQUENCY
ALS-SP	120V - 277V	10kV, 10kA, ANSI C62.41 Category C	SnapLOCK / Footed	Polycarbonate	6", 18AWG stranded, 105°C stripped, 3/8" tinned	60Hz

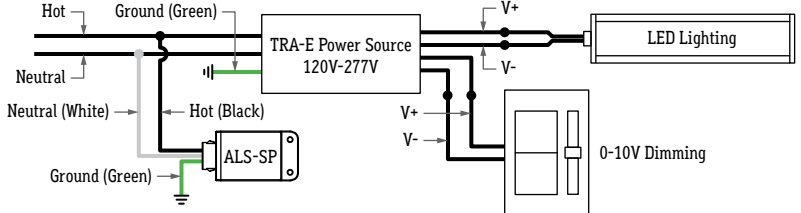
**PRODUCT FEATURES**

The Surge Series are 3-leaded devices that protect Line-Ground, Line-Neutral, and Neutral-Ground in accordance with IEEE / ANSI C62.41.2 guidelines. Protects against surges according to IEEE C62.41.2 C High (10kA and 10kV). Surge current rating = 10,000 Amps using industry standard 8/20 μSec wave. Surge Location Rated Category C3. UL Recognized Component in the United States and Canada (UL1449). Type 4 Surge Protection Device. High temperature, flame retardant plastic enclosure, 85°C maximum surface temperature rating. Thermally Protected Transient Over-voltage Circuit.

**PRODUCT SPECIFICATIONS**

The Surge series of products are designed to be used in conjunction with LED Drivers and fixtures to provide an additional level of protection against powerline disturbances in industrial, commercial and residential applications where surge protection to IEEE C62.41.2 is required.

**0-10V WIRING DIAGRAM (10V Dimming)**



**Note:** Wire colors vary based on model. See individual TRA-E submittal for more information, or refer to wire callouts on transformer labeling. Always confirm wire colors before connecting to power source.

**FORWARD PHASE WIRING DIAGRAM (Forward Phase Dimming)**

